



The Chemical Company

BASF AUSTRALIA LTD

**APPLICATION GUIDE
for
MASTERTOP 230
Heavy duty metallic-aggregate floor topping**

IMPORTANT: READ THIS FIRST

BASF Construction Chemicals does not warrant the performance of this product unless the instructions of this document and other related BASF Construction Chemicals documents are adhered to in all respects.



The Chemical Company

1. APPLICATION OF MASTERTOP 230 HEAVY DUTY METALLIC AGGREGATE-FLOOR TOPPING

- Key areas subject to heavy traffic, impact, abrasion and continuous wear
- Loading docks
- Waste transfer facilities
- Truck or heavy equipment repair areas

NOTE:

- Do not add cement, aggregate or admixtures
- Store in a dry place
- Do not use if bag is damaged

2. DIRECTIONS FOR PLACING MASTERTOP 210

These steps have been found to be an effective method of applying MASTERTOP 230 to obtain a floor which is highly impact and abrasion resistant. However, ideal characteristic results of these, or any construction product, are highly dependent upon ambient conditions, adequate labour, proper equipment, surface preparation etc.

Arrange to have a pre-job conference with your local BASF Construction Chemicals technical representative to discuss all aspects of the MASTERTOP 230 application, surface preparation, etc.

NOTE: Under rapid drying or hot, ambient conditions, MASTERKURE 111 evaporation retardant should be sprayed from a garden sprayer, according to label instructions, to prevent rapid moisture loss from the MASTERTOP 230.

3. ESTIMATING DATA

One 25kg bag mixed with 2.4 litres of potable water provides approximately 0.0077m³; of screedable topping at a 150mm slump. 3 x 25kg bags will yield 1m² & 23mm thick approximately.

4. MIXING

Using a barrel mixer, add three-fourths of the mixing water followed by the Using a barrel mixer, add $\frac{3}{4}$ of the mixing water followed by the MASTERTOP 230 in a slow, steady stream, then mix for approximately two to three minutes. Add remaining water and continue mixing for a total of five minutes, for a homogenous mix at the recommended slump.



The Chemical Company

The use of ice water will reduce the amount of water necessary for a given consistency, and will result in increased working time and strength of the topping. Do not use water in an amount or at a temperature that will cause bleeding or segregation.

Discharge the topping from the mixer for immediate placing and screeding. If lumps are present, remove.

5. SUGGESTED PROCEDURE FOR APPLYING MASTERTOP 210 OVER EXISTING, PROPERLY ROUGHENED HARDENED CONCRETE

To achieve proper bond of MASTERTOP 230 the surface of the concrete should show a 5mm amplitude. All laitance and contaminated areas must be removed; coarse stone and the aggregates shall be exposed. This is best achieved by multiple passes with a shot blast machine with heavy shot, a scabblor or scarifier. The concrete surface should be tested for tensile bond pull off strengths per BASF Construction Chemicals recommendations. The minimum tensile bond pull off strength shall not be less than 2.00MPa and substantial coarse aggregate fracture shall be revealed. The test must be performed in several locations on each slab section scheduled for placement of MASTERTOP 230. The temperature of the contact surfaces should be such that the bonding material can be applied and cured as per BASF Construction Chemicals recommendations.

Treatment of all joint edges and the perimeter of the pour can be performed in one of two fashions.

- i) Fasteners should be staggered 100mm to 150mm from the edge, 300mm to 450mm on centre, as shown in Diagram 1. The anchors shall be tested for solid embedment.



OR

- ii) Mechanically remove the substrate concrete 25mm deeper than the specified topping thickness, tapered over a 100mm width as shown in Diagram 2. Rough texture of the substrate must be provided. Anchors to be placed at 450mm centres and 50mm from joint edge to prevent thick edges curling.

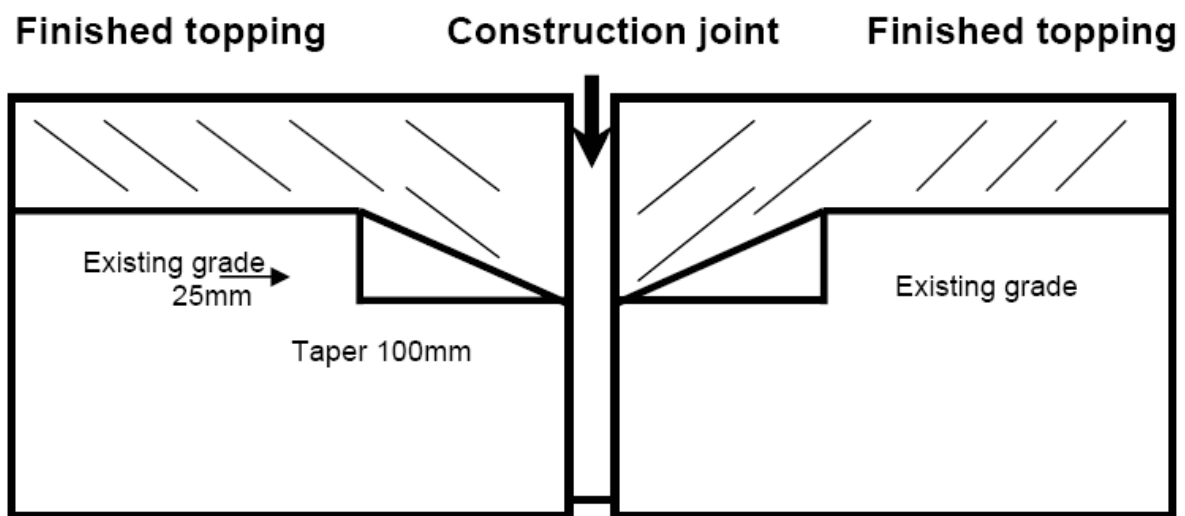
Diagram 2

Prior to the MASTERTOP 230 placement the concrete shall be tested in accordance with ASTM D-4263, (Indicating Moisture in concrete by the Plastic Sheet Method). Excessive moisture must be force-dried to produce a condition suitable to where the bonding material will achieve the proper bond strength.

BASF Construction Chemicals CONGRESIVE 2525 liquid epoxy bonding agent shall be used to bond the topping to the existing concrete. Mix according to label instructions and brush or roll on to the concrete surface. Place the topping while the epoxy is still tacky.



The Chemical Company

6. PLACING AND FINISHING

Place and screed the MASTERTOP 230 in sections that will assure that the finished elevation is maintained. Because of the relatively high slump of MASTERTOP 230, a roller or pipe screed is the preferred method for obtaining a uniformly flat, dense surface without excessive segregation from vibration. Tamp the topping thoroughly with a jitterbug to consolidate and ensure contact with the bond surface.

As soon as the MASTERTOP 230 will support an operator and machine without leaving impressions on the slab or creating excessive fines at the surface, float with a mechanical trowelling machine equipped with float shoes. For small areas, floating with hand tools is acceptable.

Following one machine floating, proceed with one or two normal trowelling operations to obtain a hard steel trowel or burnished trowel finish. Trowelling operations should be timed and blade angle adjusted to avoid blistering. Periodically measure the topping thickness, especially in the centre of the slab.

7. JOINTS

Joints and proper joint spacing is necessary to limit the cracking tendencies of the product due to shrinkage (contraction joints), movement between the floor and other structural members (isolation joints) and concluding pours from one day to another (construction joints). Procedures for base slab joint location, spacing, depth etc. should be discussed with BASF Construction Chemicals personnel. Maximum joint spacing should not exceed 6m. Base slab joints must be matched in the MASTERTOP 230 topping by forming or other suitable means.

NOTE:

For MASTERTOP 230 placement on hardened slabs when joint spacing exceeds 6m, intermediary joints must utilise anchors. See your local BASF Construction Chemicals technical representative for further recommendations.

8. CURING

Moist curing is necessary to attain the design strength, surface impermeability and wear resistance of the MASTERTOP 230. After finishing is complete and when the surface will not be marred by foot traffic, continuous mist or fog spray the surface of the topping with water and cover with weighted polyethylene sheeting for a minimum of 7 days. When mist spraying is not possible use soaker hoses with two layers of saturated burlap or similar type material and cover with polyethylene for a minimum of 7 days.



The Chemical Company

After 7 days of wet curing, and while the MASTERTOP 230 is still moist, remove excess water with a squeegee. Immediately apply two coats of MASTERKURE 100WB or 404 in cross directions using a short nap roller. The use of a roller will ensure complete coverage of the MASTERTOP 230. Do not spray curing compound and do not allow the MASTERTOP 230 to dry out prior to the application of the curing, because good application of curing compound is essential for future performance of Mastertop 230.

9. SUPPLEMENTAL INFORMATION ON MASTERTOP 210

During raised trowelling, if any blistering occurs, flatten trowel blades immediately to remove blisters. Wait until raised trowelling does not produce blisters.

For information on applications that would require special considerations, contact your local BASF Construction Chemicals technical representative.

Because MASTERTOP 230 contains iron aggregate it is an excellent conductor of both hot and cold temperatures. It can vary in dimension much more quickly than the underlying concrete thus causing potential bond failure. For these reasons, including freeze-thaw and potential oxidation of the aggregate, special care should be taken for MASTERTOP 230 use outdoors. Special precaution must be taken to mitigate these environmental conditions. (See your local BASF Construction Chemicals technical representative for specific details.)

10. CAUTION

MASTERTOP 230 contains portland cement, which in combination with water, may cause skin irritation, rash and alkali burns. Do not wear contact lenses when working with this product. Remove clothing and wash before reuse. Keep product out of the reach of children.